

# Design of Single Phase Shunt Active Filter by using p-q technique

**Dr.HENRY**

Assistant professor, Dept. of EEE,  
Christu Jyoti Institute of Technology and Science,  
Jangaon, Telangana, India

**Dr.JULIE**

Assistant professor, Dept. of EEE,  
Sumathi Reddy Institute of Technology for Women  
Warangal, Telangana, India

**ABSTRACT:** The design of single phase shunt active power filter (APF) based on instantaneous power theory. The active filter will be connected directly to utility in order to reduce total harmonic distortion (THD) of load current, in this case the utility is TNB. The instantaneous power theory also known as p-q theory is used for three phase active filter and this paper suggests that the p-q theory can also be implemented for single phase active filter. Since the system has only single phase signal for both voltage and current, thus the dummy signal with 120° different angles must be generated for input of the p-q theory. The p-q technique will generate six signals pulse width modulation PWM for switching IGBT, but only two of the signals will be used to control the switching IGBT. The simulation results are given by Simulink model to demonstrate the performance of the load current on single phase shunt active power filter.

**KEYWORDS:** active power filter (APF), total harmonic distortion (THD), pulse width modulation (PWM).

## I.INTRODUCTION

Increasing demand on power converter or others nonlinear load will cause usage of active power filter which widely applied eliminates the total harmonic distortion of load current. By generating harmonic that came from nonlinear load, will facing a serious problem in the power system such as low power factor, increases losses, reduces the efficiency and increase the total harmonic distortion. The instantaneous power theory or p-q theory was introduced by Akagi, Kanazawa and Nabae . The p-q theory was introduced and implemented only for three phase power system. Based on the term of p and q, the p-q theory will manipulate the active and reactive power in order to maintain the purely sinusoidal current waveform at three phase power supply. There are a few techniques which can be used to eliminate harmonic others than active filter namely: L-C filter and Zig-Zag transformer. These techniques facing many disadvantage either the controller or the system such as fixed compensation, possible resonance, bulkiness, electromagnetic interference, voltage sag and flicker .There are some advantages of implementing shunt active filter on grid power system since it can be installed at housing estate or others system that using single phase grid power system. The aim of this paper is to implement the p-q theory in single phase shunt active filter connected directly to grid power system. The p-q technique injects the power compensation so as to generate gating signals to switching devices of APF to minimise the harmonics in the line current. This technique is simulated by using Simulink model.

## II. MATHEMATICAL MODEL

The p-q theory also known as instantaneous power theory is widely used for three wires three phase power system and also extended to four wires three phase power system. Although this theory using three current and three voltage signals, it also can be used for single phase active filter by duplicating two more current and voltage signal with 120° angel shifting. This theory based on separation power component separation in mean and oscillating values. Consider load current of single phase load as phase “a” and others phase (phase “b” and phase “c”) are generated by duplicating technique. The load current can be assumed as phase “a” current and with be expressed mathematically as shown in eq. (1). By assuming that eq. (1) as phase “a” load current, load current for phase “b” and c can be represented as eq. (2) and eq. (3).

$$i_a = \sum_{i=0}^n \sqrt{2} I_i \sin(\omega_i + \theta_i) \quad (1)$$

$$i_b = \sum_{i=0}^n \sqrt{2} I_i \sin(\omega_i + \theta_i - 120^\circ) \quad (2)$$

$$i_c = \sum_{i=0}^n \sqrt{2} I_i \sin(\omega_i + \theta_i + 120^\circ) \quad (3)$$

Equations (1), (2) and (3) can be transformed in matrix form as shown in (4) and (5) for load current and load voltage respectively

$$\begin{bmatrix} i_a \\ i_b \\ i_c \end{bmatrix} = \begin{bmatrix} 1 \\ 1\angle 120^\circ \\ 1\angle 240^\circ \end{bmatrix} [i_a] \quad (4)$$

$$\begin{bmatrix} v_a \\ v_b \\ v_c \end{bmatrix} = \begin{bmatrix} 1 \\ 1\angle 120^\circ \\ 1\angle 240^\circ \end{bmatrix} [v_a] \quad (5)$$

Determine the  $\alpha$  and  $\beta$  reference current by using Clarke transformation as shown in (6) for load current and in (7) for load voltage.

$$\begin{bmatrix} i_\alpha \\ i_\beta \\ i_o \end{bmatrix} = \sqrt{\frac{2}{3}} \begin{bmatrix} 1 & -\frac{1}{2} & -\frac{1}{2} \\ 0 & \frac{\sqrt{3}}{2} & -\frac{\sqrt{3}}{2} \\ \frac{1}{\sqrt{2}} & \frac{1}{\sqrt{2}} & \frac{1}{\sqrt{2}} \end{bmatrix} \begin{bmatrix} i_a \\ i_b \\ i_c \end{bmatrix} \quad (6)$$

$$\begin{bmatrix} v_\alpha \\ v_\beta \\ v_o \end{bmatrix} = \sqrt{\frac{2}{3}} \begin{bmatrix} 1 & -\frac{1}{2} & -\frac{1}{2} \\ 0 & \frac{\sqrt{3}}{2} & -\frac{\sqrt{3}}{2} \\ \frac{1}{\sqrt{2}} & \frac{1}{\sqrt{2}} & \frac{1}{\sqrt{2}} \end{bmatrix} \begin{bmatrix} v_a \\ v_b \\ v_c \end{bmatrix} \quad (7)$$

The active and reactive power is written as:

$$p = v_\alpha i_\alpha + v_\beta i_\beta + v_o i_o \quad (8)$$

$$q = v_\alpha i_\alpha - v_\beta i_\beta \quad (9)$$

$$\begin{bmatrix} p \\ q \end{bmatrix} = \begin{bmatrix} v_\alpha & v_\beta \\ -v_\beta & v_\alpha \end{bmatrix} \begin{bmatrix} i_\alpha \\ i_\beta \end{bmatrix} \quad (10)$$

Active power and reactive power consist of two part which are mean part and oscillating part also known as DC part and AC part. The equations of active power and reactive power can be given as:

$$p = \bar{p} + \tilde{p} \quad (11)$$

$$q = \bar{q} + \tilde{q} \quad (12)$$

The DC part can be calculated by using low-pass filter, which is can remove the high frequency and give the fundamental component or the DC part. From DC part active power and reactive power, the  $\alpha$ - $\beta$  reference current can be represented in (13).

$$i_{\alpha\beta} = \frac{1}{\Delta} \begin{bmatrix} v_\alpha & v_\beta \\ v_\beta & -v_\alpha \end{bmatrix} \begin{bmatrix} p \\ q \end{bmatrix} \quad (13)$$

Where  $\Delta = v_\alpha^2 + v_\beta^2$

The three phase current reference of active power filter is given in (14) before the signal will subtracted to load current. The subtracted three phase current will be used to generated PWM signal using hysteresis band. Hysteresis band will produce six PWM signals and for single phase active filter it is only two are used as input of hysteresis band.

$$i_{abc}^* = \sqrt{\frac{2}{3}} \begin{bmatrix} 1 & 0 \\ -\frac{1}{2} & \frac{\sqrt{3}}{2} \\ -\frac{1}{2} & -\frac{\sqrt{3}}{2} \end{bmatrix} i_{\alpha\beta}^* \quad (14)$$

### III. SINGLE PHASE SHUNT ACTIVE FILTER

Single phase shunt active filter consists of supply utility single phase, single phase rectifier, single phase active filter, controller and load.

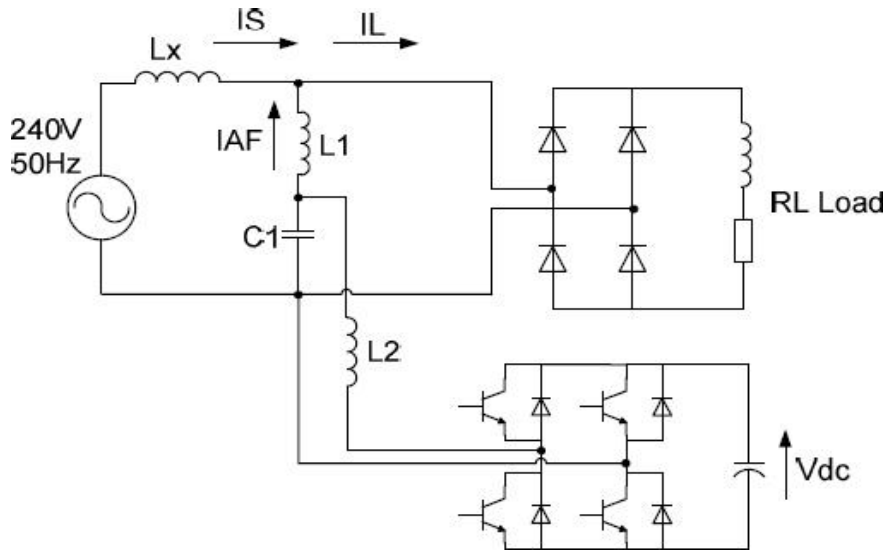

**Fig. 1: Schematic diagram of single phase shunt active filter**

Schematic of single phase shunt active filter is shown in Fig. 1. They are two kinds of active power filter such as current source active filter and voltage source active filter. The different between these two topologies is the storage element. Current source active filter will use inductance as the storage element mean while voltage source active filter use capacitance as the storage element.

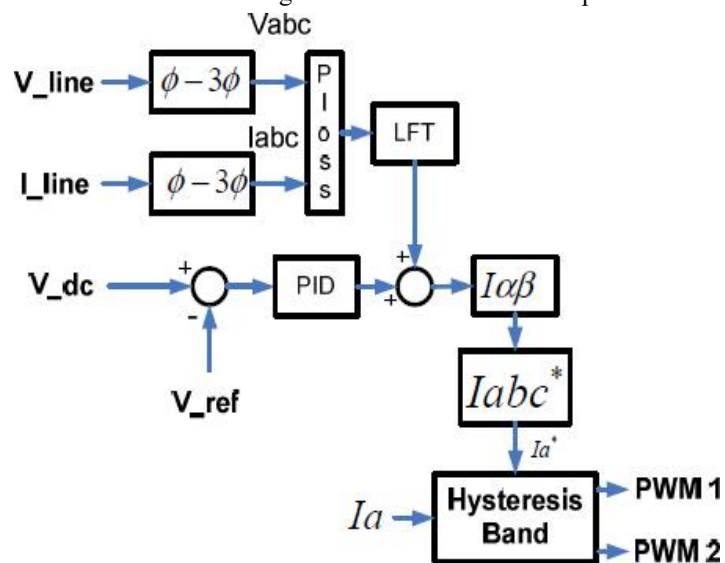
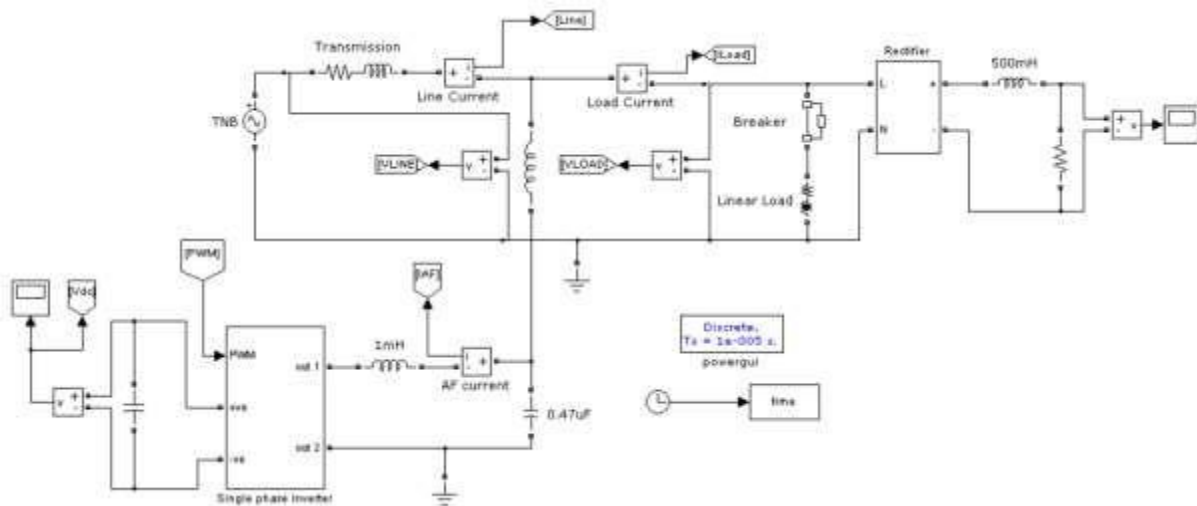

**Fig. 2: Control strategy**

Fig. 2 shows the control strategy based on p-q theory that is used to generate PWM signal for single phase shunt active filter. The simulation of single phase shunt active filter uses this control strategy on Simulink model.

### IV. SIMULATION RESULTS

A simulation of single phase shunt active filter is simulated using Simulink.



**Fig. 3: Modelling of single phase active filter**

The simulation use single phase system 230V 50Hz directly from TNB as shows in Fig. 3. The non-linear load with 3KVA for compensation is connected before single phase diode rectifier.

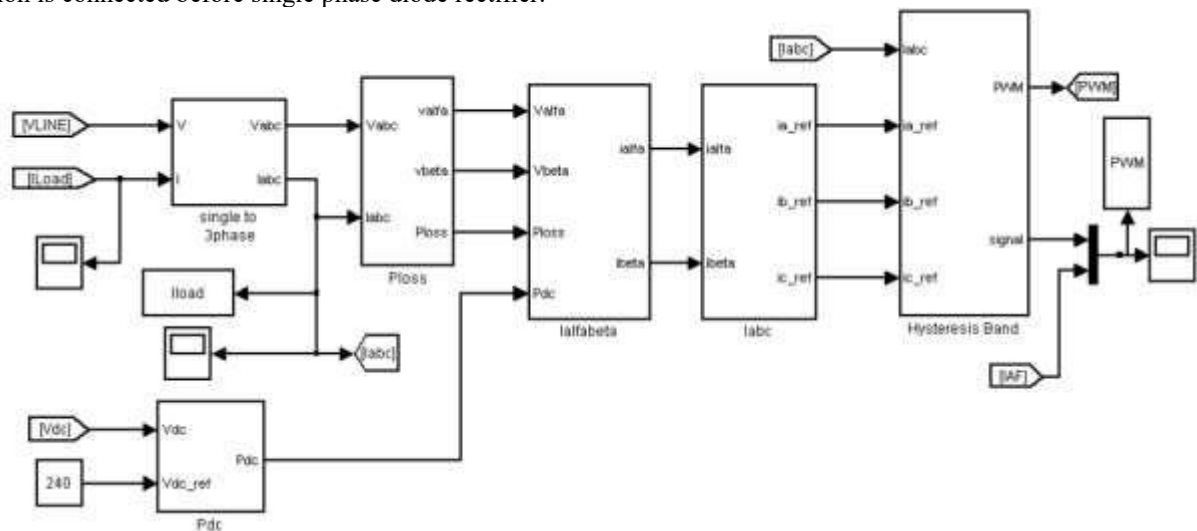

**Fig. 4: Modelling of p-q theory**

Fig. 4 shows the modelling of p-q theory which consists of single to three phase block, algebra transformation of p-q theory three phase to two phase, two phase to three phase transformation and hysteresis band. Hysteresis band will produce six signals PWM and for single phase active filter only use two signals to control the single phase active filter.

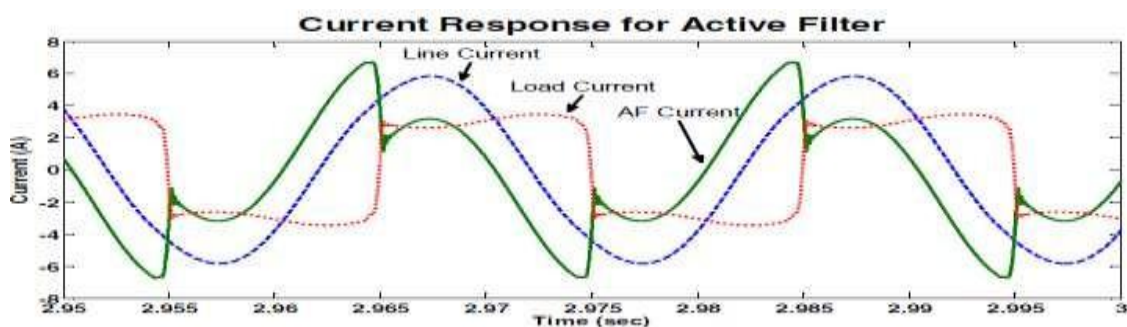

**Fig. 5: Current response for single phase active filter**

Current response for single phase active filter is shown in Fig. 5 which shows line current is a pure sine wave whereas load current is near to a square wave which consists of harmonics by using single phase active filter these harmonics are mitigated to keep THD in the specified limits.

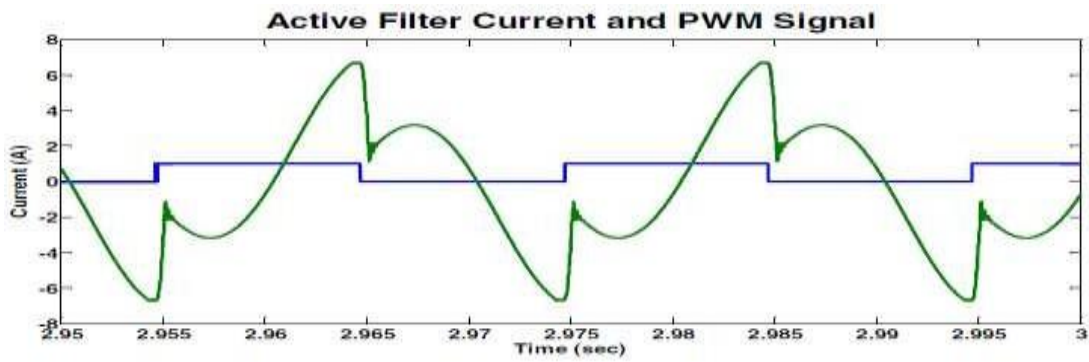

**Fig. 6: Active filter current and PWM signal**

Switching PWM signal and the active filter current are shown in Fig. 6 the positive pulse shows an increase in active filter current whereas negative pulse shows decrease in active filter current.

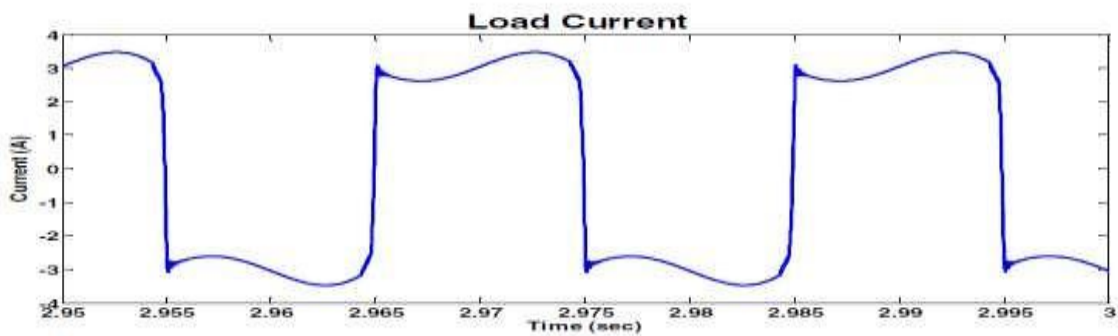

**Fig. 7: Load current**

The load current in Fig. 7 is rich in harmonics which results additional heating and derating of the system therefore, this load current is to be compensated.

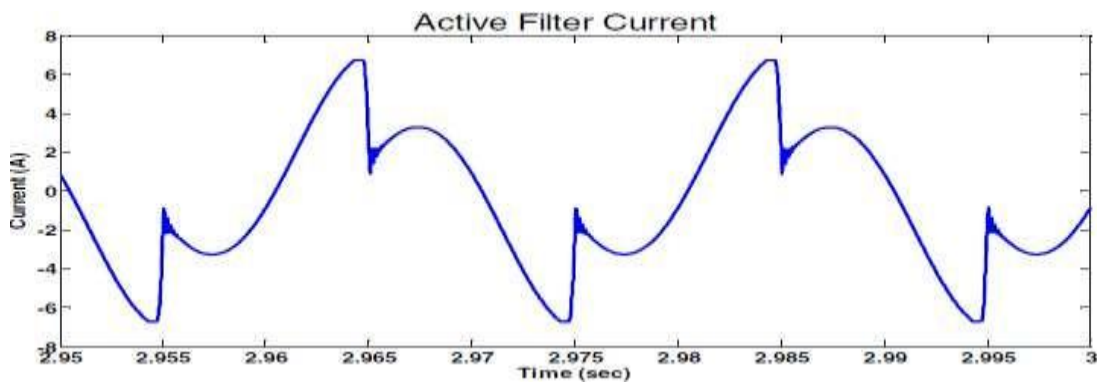

**Fig. 8: Active filter current**

The load current is compensated by injecting active filter current as shown in Fig. 8, so that the line current will be maintained as pure sinusoidal waveform.

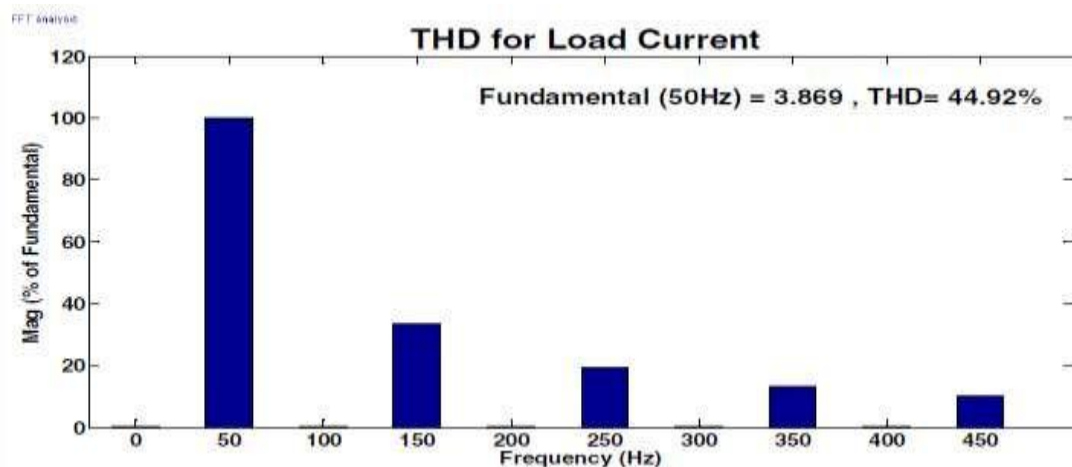

**Fig. 9: THD for load current**

The THD gives the quality of the ac system Fig 9 shows the THD of the non-linear load of the system which contains odd harmonics and will make the THD of load current increase up to 44.92%.

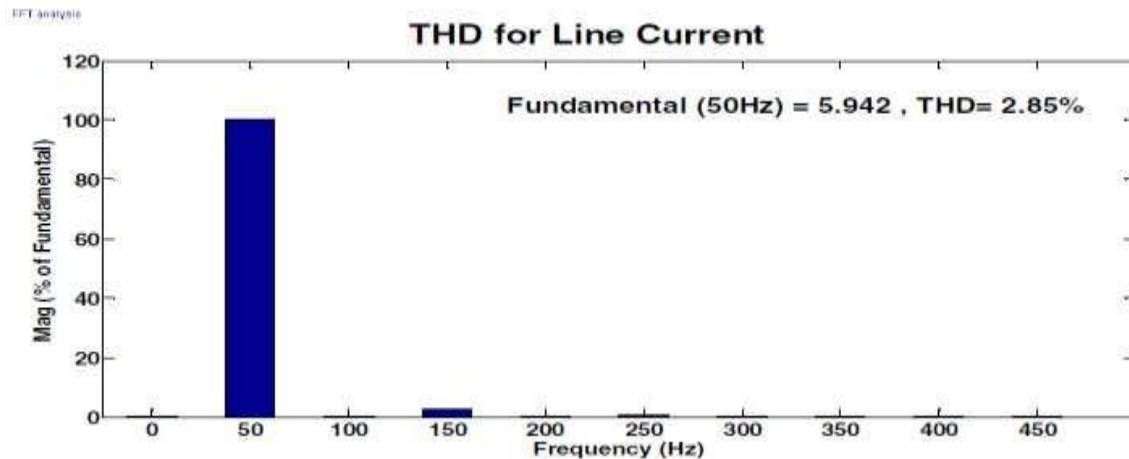
**Fig. 10: THD for line current**

THD for line current is shown in Fig 10 in which by injecting the active filter current the THD of line current will reduce to 2.85% .by using this technique harmonics are mitigated.

## V. CONCLUSION

In recent years the increasing usages of non-linear load facing of harmonic and power factor problem in power system. Many technique or topologies can be used to eliminate harmonics from power system; one of the techniques is active power filter. This paper proves that p-q theory can be implemented to control single phase active filter, which the theory widely used to control three phase active power filter. It is discovered from simulation that by implemented the p-q theory the THD of the load current can be reduced from 44.92% to 2.85%.

## REFERENCES

- [1] M.-S. Karbasforooshan, and M. Monfared, "Design and implementation of a single-phase shunt active power filter based on PQ theory for current harmonic compensation in electric distribution networks," in IECON 2017 - 43rd Annual Conference of the IEEE Industrial Electronics Society.
- [2] M.-S. Karbasforooshan, and M. Monfared, "An adaptive recursive discrete Fourier transform technique for the reference current generation of single-phase shunt active power filters," in 2016 7th Power Electron. Drive Syst. Technol. Conf. (PEDSTC), pp. 253-259, Feb. 2016.
- [3] N. A. Rahim, S. Mekhilef, and I. Zahrul, "A single-phase active power filter for harmonic compensation," Industrial Technology. IEEE International Conference, 2006, pp. 1075- 1079.
- [4] K. Ryszard, S. Boguslaw, and K. Stanislaw, "Minimization of the source current distortion in systems with single-phase active power filters and additional passive filter designed by genetic algorithms," Power Electronics and Applications, European Conference, 2006, p. 10.
- [5] A. Emadi, A. Nasiri, and S. B. Bekiarov, Uninterruptible power supplies and active filters: CRC, 2005.
- [6] H. Akagi, E. H. Watanabe, and M. Aredes, Instantaneous power theory and applications to power conditioning: Wiley-IEEE Press, 2007.
- [7] D. W. Hart, Introduction to power electronics: Prentice Hall PTR Upper Saddle River, NJ, USA, 1996.
- [8] M. McGranaghan, "Active filter design and specification for control of harmonics in industrial and commercial facilities," Knoxville TN, USA: Electrotek Concepts, Inc., 2001.
- [9] S. Round, H. Laird, R. Duke, and C. Tuck, "An improved three-level shunt active filter." vol. 1: Power Electronic Drives and Energy Systems for Industrial Growth International Conference, 2004, pp. 87-92.