

# HANDICAPPED STEERING PROPULSION TRICYCLE

**Dr Henry**

Assistant Professor

Department of Mechanical Engineering  
Christu Jyothi Institute of Technology & Science  
Colombonagar, Yeshwanthapur, Jangaon.

**Dr Arvind Prasad**

Assistant Professor

Department of Mechanical Engineering  
Christu Jyothi Institute of Technology & Science  
Colombonagar, Yeshwanthapur, Jangaon.

## ABSTRACT

The goal of this tricycle was to create an accessory, to be installed on a standard wheelchair, which would allow full control of the wheelchair with only one arm/hand while addressing areas lacking in commercial products and previous designs, such as manufacture ability, attendant control, user comfort and ergonomics. After preliminary testing and analysis of three one-arm propulsion designs, the project team developed a design for a removable, lever-operated accessory which could be adapted to fit a range of the most popular standard wheelchair models. The propulsion system, connected to the main lever by a coupler link, consists of a dual gear-pawl assembly in which the desired direction of motion is chosen by moving a shifter to engage one of the two gears press-fit around clutches, each of which allows motion in only one direction, either forward or reverse. By including a neutral pawl position in which neither clutch is engaged, this design allows an attendant to propel and control the chair. . A large verity of mobility vehicles are available, form which one is to be selected as per requirements. Mobility vehicles are designed based on the usage, i.e. either indoor or outdoor. The cost of vehicle may not be affordable for a common man. So the focus is laid on the simplicity in design, high performance, easy maintenance & safety at very reasonable price. This paper provides detail of component used & designing parameters takes in consideration while designing the tricycle. This tricycle is very efficiently designed and can be proved as a better replacement for the indigenious models used by the handicapped keeping in mind the factors such as safety, cost & performance.

**Keywords:** Single Slider Cranks Drive Mechanism, Steering, Tricycle, Wheel Chair.

## I.INTRODUCTION

Worldwide, 100-130 million people need wheelchairs, but less are not available. It is predicted that these figures will rise by 22% over the next ten years for a number of reasons, including but not limited to the aging babyboomer generation, ongoing wars, re-habitation of areas infested with land mines from prior conflicts, and other injuries and diseases. Current wheelchair technology is relatively well established in that there is not a great deal of variation in the wheel chair market, which can create difficulties for individuals whose needs are not met by currently available model.

Wheelchair design and functionality as a whole has been greatly improved over the past several decades, but there is still a need for new technology and innovative designs. The majority of assistive device users are over Age 65, with increases expected as the baby boomers age and the average life expectancy increases. Many of theConditions that restrict an individual to reliance on a wheelchair also limit control of the upper extremities to the extent that the use can only operate the chair with one hand. Disability could be caused by birth, by injuries

sustained mainly from motor accidents or during turnkey project work or in manufacturing industries as well those caused naturally. A hand tricycle works in the same way as a bicycle as it uses a chain system with pedals to drive the wheels, Except in the case of hand tricycle, the chain is attached to hand pedals instead of that we use single slider mechanism which allow the user much more efficient propulsion than would be provided from the hand pedal on wheelchair

## **II. ABOUT TRI CYCLE**

Due to the enormous number of disabled people in the society, a wheelchair tricycle has been fabricated and designed to specification. In response to demand of wheelchair user for equal access, hand-propelled wheelchair, electrically controlled wheelchair, and automated guided wheelchair have been developed.. The wheelchair is simple in construction, the tricycle wheelchair is easy to operate and the maintenance of wheelchair is very less. Overall wheelchair dimensions (minus accessory) shall not exceed 1300mm x 700mm x 1090mm (50" x 26" x 40"). [length x width x height].

## **III. TRI CYCLE SYSTEM**

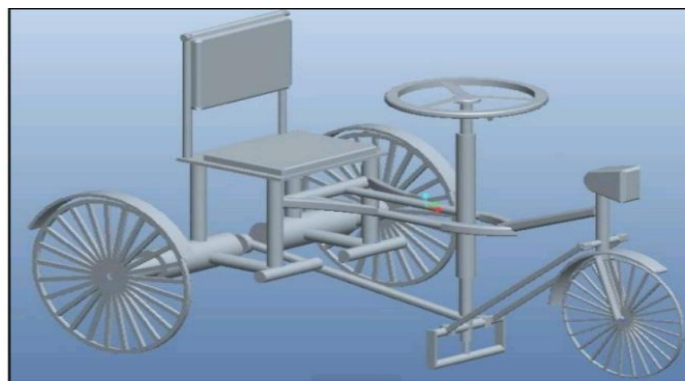

Fig 1. TRI CYCLE System

The tricycle wheelchair is work on the single slider mechanism which is operated by steering. On comparison with old traditional hand pedal wheelchair which have of chain mechanism, instead that we use single slider mechanism. Complete mechanical system in which the single slider mechanism is the main component. On that single slider mechanism a steering is mounted for operating the tricycle, which define the direction to tricycle and used to take turning to the left or right. Complete mechanical system in which the single slider mechanism is the main component. On that single slider mechanism a steering is mounted for operating the tricycle, which define the direction to tricycle and used to take turning to the left or right.

## **IV. CRANK MECHANISM**

**Crank (mechanism)** A crank is an arm attached at right angles to a rotating shaft by which reciprocating motion is imparted to or received from the shaft. It is used to convert circular motion into reciprocating motion, or vice versa.

A slider crank mechanism converts circular motion of the crank into linear motion of the slider. In order for the crank to rotate fully the condition  $L > R + E$  must be satisfied where R is the crank length, L is the length of the link connecting crank and slider and E is the offset of slider . A slider crank is a RRRP type of mechanism i.e. It has three revolute joints and 1 prismatic joint. The total distance covered by the slider between its two extreme

positions is called the path length. Kinematic inversion of slider crank mechanisms produce ordinary and Whitworth quick return mechanism.

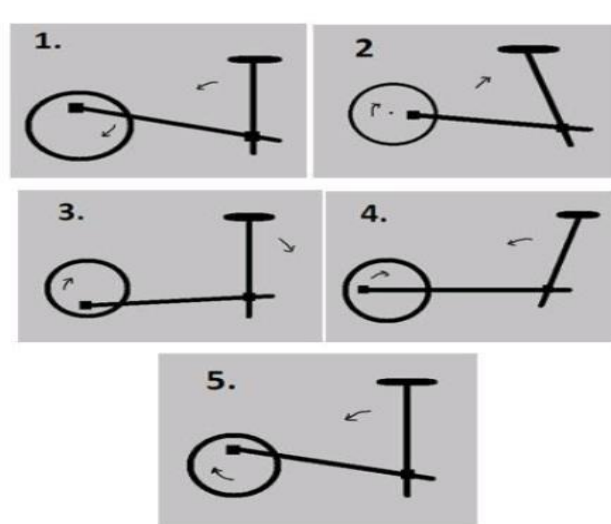

Fig2. FUNCTIONAL BLOCK DIAGRAM OF TRICYCLE

### V.MECHANICAL CONSTRUCTION

Manufacturing engineering or manufacturing process are the steps through which raw materials are transformed into a final product. The manufacturing process begins with the product design, and materials specification from which the product is made. These materials are then modified through manufacturing processes to become the required part.

Manufacturing takes turns under all types of economic systems. In a free market economy, manufacturing is usually directed toward the mass production of products for sale to consumers at a profit. In a collectivist economy, manufacturing is more frequently directed by the state to supply a centrally planned economy. In mixed market economies, manufacturing occurs under some degree of government regulation.

### CLASSIFICATIONS OF MANUFACTURING PROCESSES

Manufacturing processes classified as given below

- Machining
- Joining
- Moulding
- Forming
- Casting

### VI. COMPONENTS

In the manufacturing of tri cycle, the following components designed as per following specifications.

Sr. no	Name of part	Material	Quantity	Dimensions
1.	Rim	Steel	3	Big rims 1 m Small rim 2inches
2.	Rod	Steel	4	90 cm
3.	Seat	Plastic	1	35inch*35inch

4.	Brake wire	Rubber and steel	2	120cm
5.	bearing	Steel	6	20mm
6.	Drive shaft	Mild steel	2	16 cm
7.	Brake lever	Plastic	2	6cm

Table no.1

## VII CALCULATIONS

Weight of tricycle=35 Kg

Weight of disable people = 60 Kg (maximum condition)

Diameter of wheel = 60cm = 0.6m

N=100 rpm (maximum condition)

**A. For considering total weight (wt. of tricycle + wt. of disable people)  $W = 2\pi \times N/60$**

$$= 2\pi \times 100/60$$

$$= \mathbf{10.47 \text{ rad/sec}}$$

$$\text{Velocity} = w \times r$$

Total force = total weight

$$= \mathbf{95 \text{ kg}}$$

$$= 95 \times 9.81$$

$$= \mathbf{931.95 \text{ N}}$$

$$\text{On each wheel, } F_1 = F_2 = 465.97 \times 0.3$$

$$\text{Torque} = F_1 \times r$$

$$= 465.95 \times 0.3$$

$$= 139.79 \text{ Nm}$$

So effort required,  $T = \text{effort} \times \text{distance of link}$

$$\text{Effort} = 139.79 \times 10^6 / 1200$$

$$= 116.4 \text{ N}$$

$$= 11.87 \text{ Kg}$$

For half revolution, Effort = 5.93 kg

$$\text{Power} = 2\pi NT/60$$

$$= 2\pi \times 100 \times 139.79$$

$$= 1.463 \text{ kw}$$

Speed,  $V = 3.14 \text{ m/sec}$

$$V = 11.3 \text{ km/hr}$$

Calculation for diameter of shaft

$$\text{Formula for diameter, } T = \pi \times F_s \times d^3 / 16$$

Where, T = torque  $F_s =$

Ultimate shear streanth  $d =$

diameter of shaft

Material for shaft is carbon steel (mild steel), SAE 1010 ( Hot rolled )

Ultimate tensile strength,  $S_{ut} = 379 \text{ mpa}$

We have a relation ,  $S_{us}/S_{ut} = 0.75$

So we get ,  $S_{us} = F_s = 284.25 \text{ Nmm}^2$

Therefore ; Diameter of shaft

$$139.79 \times 10^3 = \pi \times 284.5 \times d^3 / 16 d$$

$$= 13.58 \text{ mm}$$

**Design values as per calculations:**

Weight of tricycle with steering mechanism = 35 kg

Weight of disable people = 60 kg

Effort required = 11.87 kg

Speed of tri cycle = 11.3 km/hr

Diameter of shaft = 14 mm

### VIII. CONCLUSION

In this tricycle we utilized single slider mechanisms for operating tricycle hence it is most useful and economical as compared to the other tricycle. This tricycle is made of material which is available easily in market. This tricycle is mostly useful for elder and handicapped people. It is simple in design and easy to operate. The efforts made for operating tricycle is less this is an advantages of this tricycle. The tricycle cost is less as compare to other tricycle. The purposed of single slider linkage installed on rear wheel of tricycle, which therefore can capable to accelerate with suitable comfortable motion. A single slider mechanism for rear wheel is ensured through an easily controlled motion, and compactness of mechanism design makes it suitable for wheelchair cum tricycle for aiding people with disabilities.

### IX. REFERENCES

- [1] Erickson, William, Camille G. Lee, and Sarah von Schrader. "2008 Disability Status Reports: United States." (2010)
- [2] Lesley, Samuel, and Lucy A. Porter. "An ergonomic wheelchair for hemiplegics." *Technology and Disability* 14.4 (2002): 183-189.
- [3] Cyders, Timothy J. *Design of a Human-Powered Utility Vehicle for Developing Communities*. Diss. Ohio University, 2008.
- [4] Fries, Richard C. *Reliable design of medical devices*. CRC Press, 2012
- [5] La Plante, Mitchell P., and Disability Statistics Center. "Demo-graphics of wheeled mobility device users." *Conference on space requirements for wheeled mobility*. Buffalo, New York: Center for Inclusive Design and Environmental Access, 2003.